

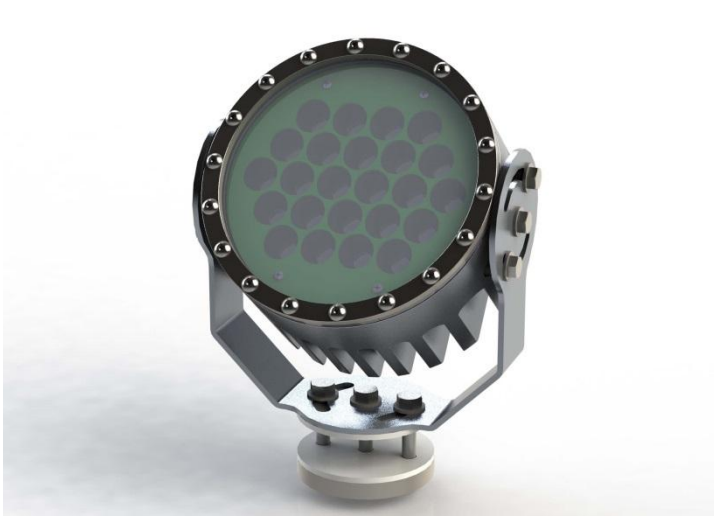

NewtSun 500



Producing an unheard of 65,000 Lumens, with a CRI of 80 and colour temperature of 5000K, the NewtSun 500 has little competition. The NewtSun 500 body is milled from 6061T6 aluminum billet and hard anodized.

Optical performance is thanks to the latest CREE CXB LEDs, which produce a market leading 131 lumens per watt. Nuytco's universal, high efficiency power supply retains the fixtures net luminous efficiency at 124 lumens per watt.

The fixture is AC/DC universal (90-350VDC, 120-240VAC), power factor corrected, and is thermally protected. Low power (250W) /high power mode is selected by toggling power off and on.

Note that the Newtsun 500 is intended for use in water, but can be run in air safely for approximately five minutes.

Nuytco Research Ltd

216 East Esplanade, North Vancouver
B.C. V7L 1A3 Canada

Phone: 604 980 6262
Email: nrl@nuytco.com
Web: www.nuytco.com



NewtSun 500

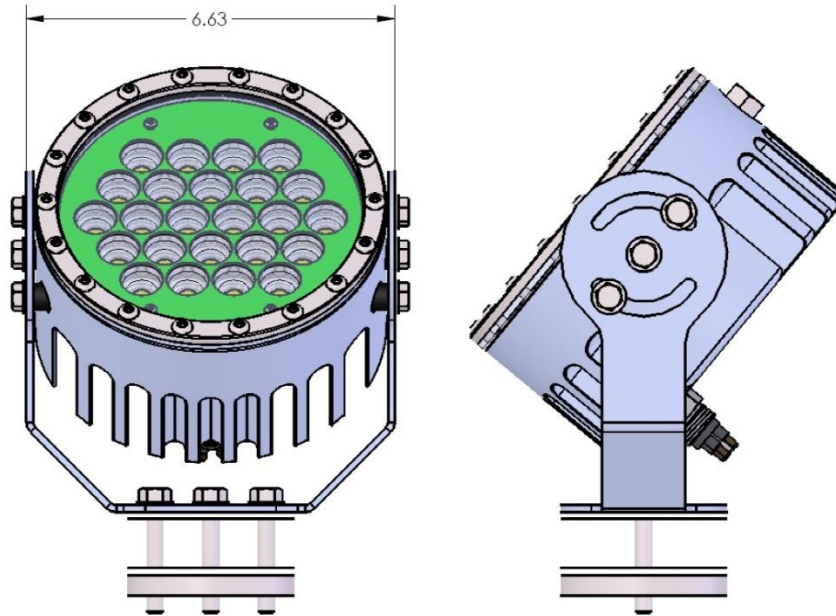

Specifications:

Voltage Input: 90-350 VDC or 120-240 VAC

Power dissipation: 535 W

Luminous Flux: 65,000 lm

Color Temperature: 5000K

Color rendering (CRI): 90

Beam angle: 47 deg

Depth rating: Full ocean (PBOF)

Air weight: 9.9 lbs.

Water weight: 6.5 lbs.

Bulkhead: SubConn MCBH3MAL

Warranty: 2 Year*

* warranty covers internal electronics only

Nuytco Research Ltd

216 East Esplanade, North Vancouver
B.C. V7L 1A3 Canada

Phone: 604 980 6262
Email: nrl@nuytco.com
Web: www.nuytco.com