

# NMT12-Mk2 Thruster



**Nuytco's** second generation magnetically coupled 12 inch thruster improves on the excellent power and reliability of the first generation NMT12 by incorporating the drive right into the thruster housing. These units have been optimized, above all, for bollard efficiency – they produce outstanding thrust at any power setting.

A magnetically coupled prop shaft means that there are no dynamic seals and the housing is not oil filled. Should the thruster jam due to foreign object ingestion the coupling will slip, resulting in no electrical or mechanical damage.

The high torque motor eliminates the need for a transmission, further enhancing reliability and making the thruster extremely quiet. Low rotor inertia allows for nearly instantaneous windup, and dynamic breaking allows for very quick reversal and precise stopping.

The **NMT12-Mk2** also monitors its supply voltage to maintain thrust output should its input voltage droop.

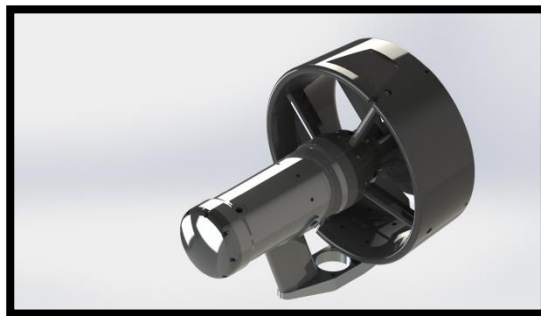

## Nuytco Research Ltd

216 East Esplanade, North Vancouver  
B.C. V7L 1A3 Canada

Phone: 604 980 6262  
Email: [nrl@nuytco.com](mailto:nrl@nuytco.com)  
Web: [www.nuytco.com](http://www.nuytco.com)



# NMT12-Mk2 Thruster

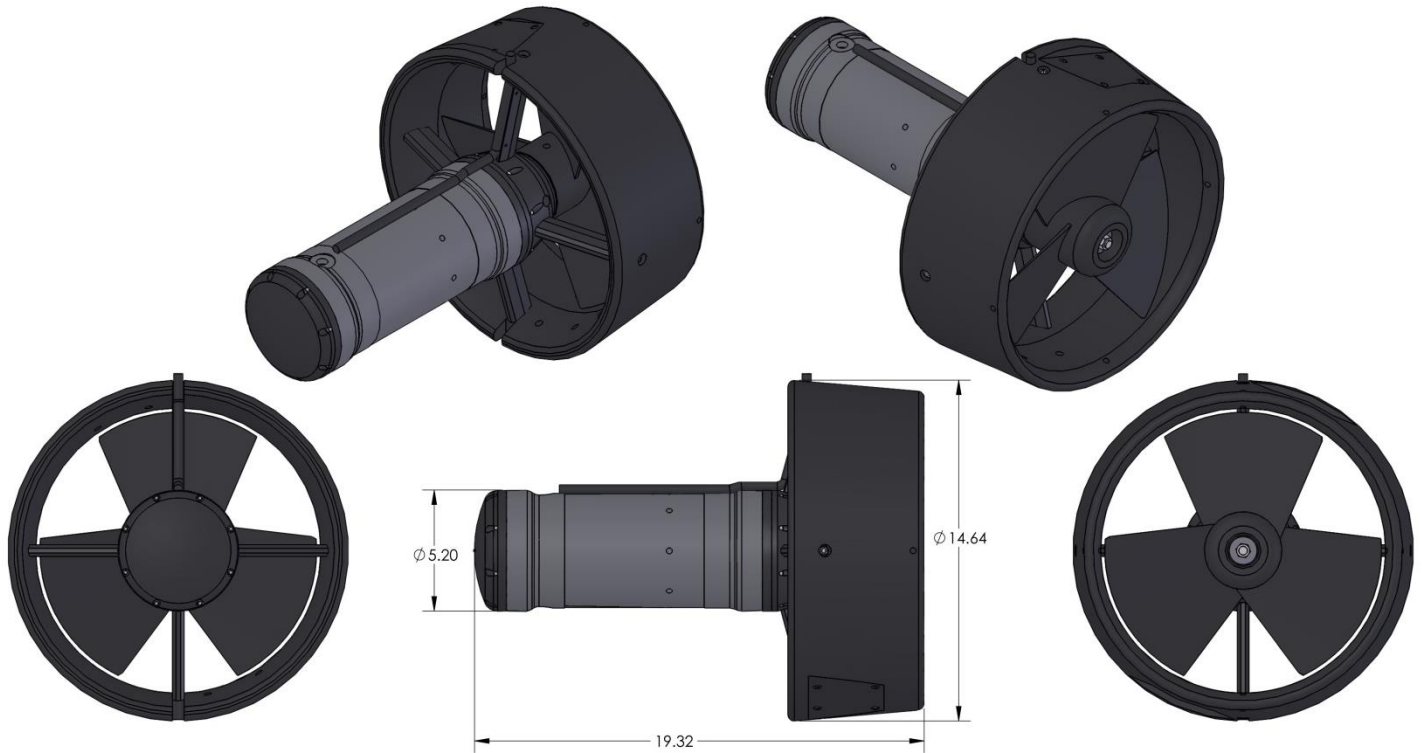

## Specifications:

**Voltage Input:** 200-300 VDC  
**Motor type:** Brushless DC  
**Depth rating:** 1000m (2000m optional)  
**Air weight:** 48 lbs.  
**Water weight:** 27.5 lbs.  
**Control:** +/- 10 VDC  
**Bulkhead:** Impulse PNA-1/2"-RA-AL  
**Connector:** Impulse MHDG5 -CCP  
**Standard cable length:** 8 feet

## Bollard Thrust:

Hp (input)	Kw (input)	Thrust (pounds)
1	.75	70
2	1.5	100
3	2.2	120
3.3	2.5	140
4	3	160

**Nuytco Research Ltd**

216 East Esplanade, North Vancouver  
B.C. V7L 1A3 Canada

Phone: 604 980 6262  
Email: [nrl@nuytco.com](mailto:nrl@nuytco.com)  
Web: [www.nuytco.com](http://www.nuytco.com)